

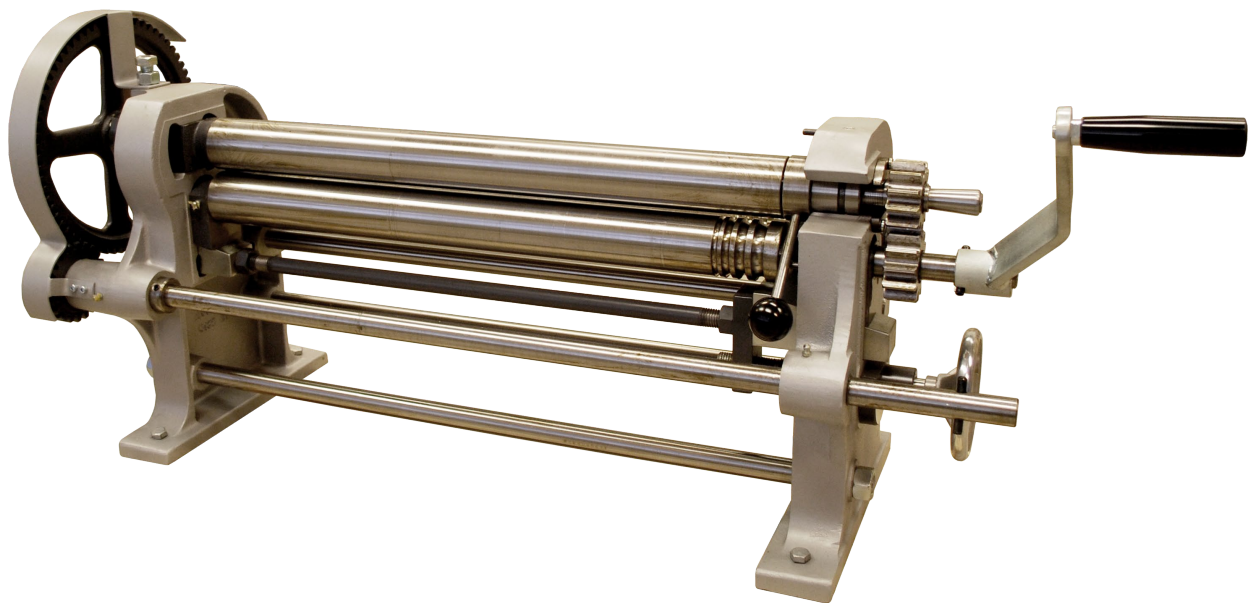

nosstec



Bending Roll Machine 4132

OPERATING INSTRUCTIONS

TABLE OF CONTENTS



Main components	4
Operation	5
Safety	7
Service and maintenance	12
Lubrication / Grease chart	13
Machine plates and stickers	14
Dismantling of bending roller	15
Contact information	See back

Note: We reserve the right to alter specifications without prior notice.

For copyright reasons all reproduction and copying of the texts, tables and illustrations within this manual is prohibited without written permission from Nosstec AB.

MAIN COMPONENTS

Front side

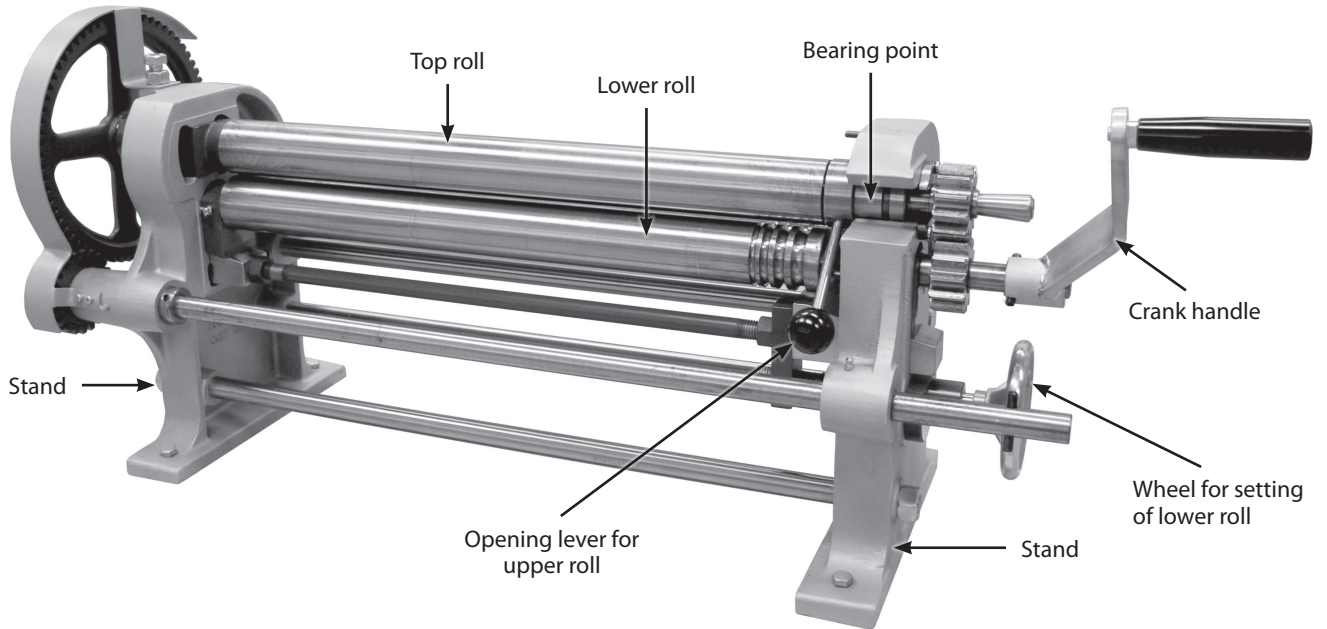

Back side

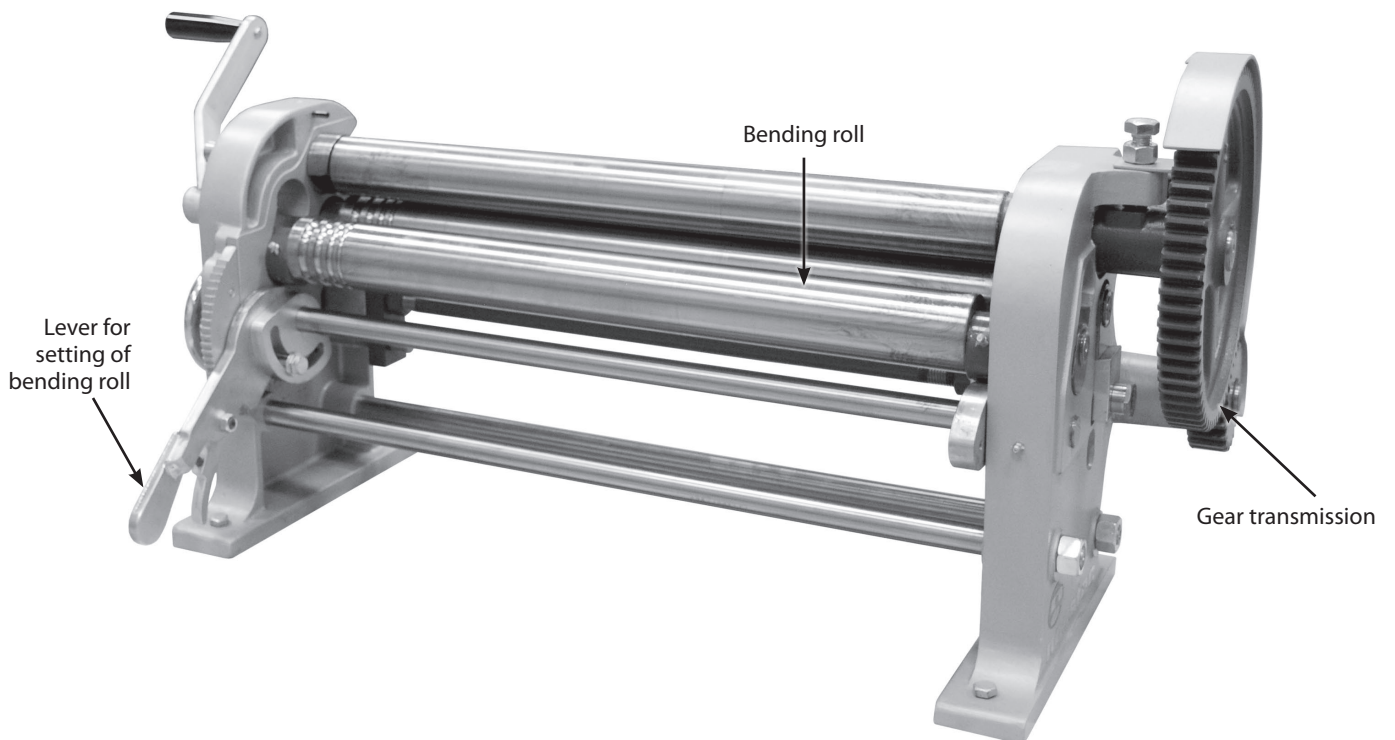

Disclaimer: The machine pictured on this page is not necessarily representative of the actual product as delivered. Differences in sizes, options and/or accessories may or may not be pictured here.

Prebending

In order to give the workpiece a symmetrically round shape, it is necessary to prebend the part of the workpiece, which should be bent first.

This must be made from the back of the machine and with the rolls rotating in the opposite direction (see picture 1 in the figure on the right).

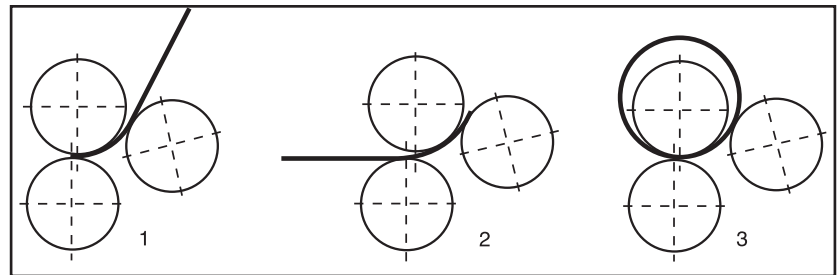

Bending

Place the bending roll in the required position (see setting diagram below).

Introduce the prebent workpiece between the upper and lower rolls and use the bending roll as a back gauge.

Turn the hand wheel of the lower roll so that the workpiece is clamped between the rolls. Bend the sheet (check that the sheet runs above the bending roll as per picture 2 in the figure above).

Adjust the bending roll and repeat the operation until the workpiece has got the desired shape. Swing out the top roll and remove the workpiece. Swing back the top roll into its initial position.

At the maximum operating length and the maximum sheet thickness tubes down to about 1,5 times the diameter of the upper roll can be formed and for thinner sheets down to about 1,2 times the diameter of the roll.

When bending steel sheet or stainless steel the maximum thickness capacity of the machine will be reduced to about $\frac{2}{3}$ compared to mild carbon steel sheet.

OPERATION

Removal of workpiece

The finished workpiece is removed from the machine as follows:

- Swing out the upper roll by raising the lever with the bakelite knob. The upper roll is now free and can be moved sideways.
- The finished sheet can now be easily removed.

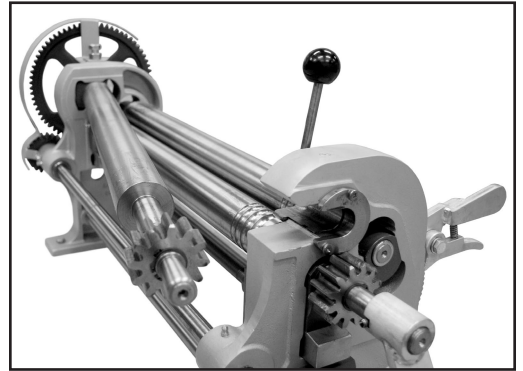

Cone bending

In order to facilitate cone bending, the bending roll can be set diagonally as follows:

- Loosen the internal hexagon screw on the handle on the right hand back side of the bending roll.
- Adjust the cam so that the required diagonal setting is obtained.
- Tighten the screw.

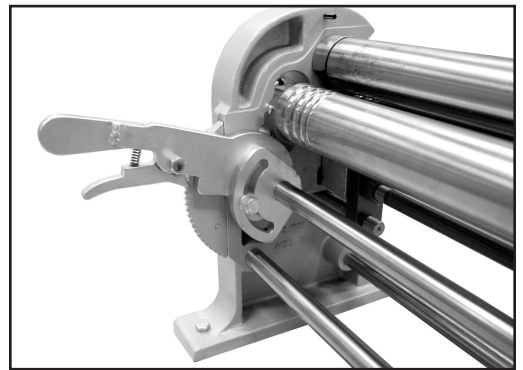

To reset, see "Parallel adjustment of rolls".

Parallel adjustment of rolls

The parallelism of the lower- and bending rolls in relation to the upper roll is set by pressing the roll in question towards the upper roll. Loosen the internal hexagon screw and turn the handle as much as possible. Set the released cam for the horizontal position and tighten the internal hexagon screw.

General

This machine is designed with a view to eliminating personal injuries provided that the instructions in this manual are being followed.

Only authorized and trained staff is allowed to use the machine. Read the whole instruction manual and make sure that you understand the contents before the machine is taken into use. It is important that you read the safety instructions below:



Safety instructions in connection with the installation

The machine must be bolted to the floor with 4 pcs expansion shell bolts or to stand (accessory).

Lifting instructions

This machine must be lifted by truck as long as it is packed in a crate or a wooden case. When lifting it from the packing to the permanent working site an approved lifting device type travelling crane must be used. Instructions for lifting by means of travelling crane:

1. Check that the top roll is in the locked position.
2. Put a lifting sling around the rolls as per figure.
3. Lift carefully at the same time as you check that the rolls are pressed together.

Regarding weights, see machine plate on the machine.

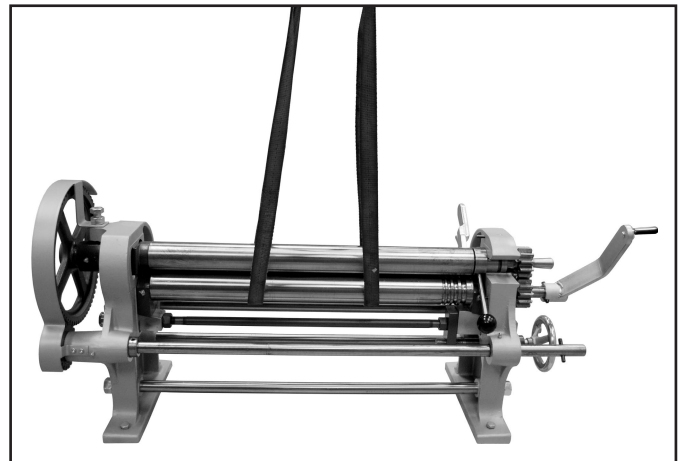

SAFETY



Application

Never use the machine for material which is outside the capacity range of the machine. Check the machine plate for more information.

Before the machine is operated the following steps must be taken:

Check that all safety devices function and that they are not damaged. Also check that moveable parts are not exposed to obstacles e.g. owing to incorrectly mounted guards or parts. Broken parts or safety components must be changed by authorized staff. Contact Nosstec in case spare parts are needed. The machine has a 24 month applicable warranty from date of delivery. The warranty is only applicable as long as original spare parts are used.

Check that the environment around the machine is suitable

- Do not expose the machine to rain.
- Do not use the machine in wet or damp premises.
- Check that the lighting of the premises is satisfactory.
- The floor must be clean, dry and free from oil and grease spots.
- Never use easily inflammable material close to the machine.
- Dirty working sites increase the risk of accidents.

Avoid unstable working positions

Check that the operator always has a secure and stable working position.

Do not keep tools on the machine

Remove all tools from the machine before it is operated.



All repairs must be carried out by authorized staff

The machine has been made according to valid safety rules. All repairs must be carried out by trained and qualified staff. Only original spares must be used.

Note: If the repairs also involve dismantling of the machine, this must be carried out according to the enclosed dismantling instruction. This instruction must not be kept together with the machine.



Danger zone

In connection with production work check that no part of the body comes too close to the infeed side of the clamping rolls of the machine (see figure).

Note: The infeed side may vary owing to the direction of rotation of the rolls.

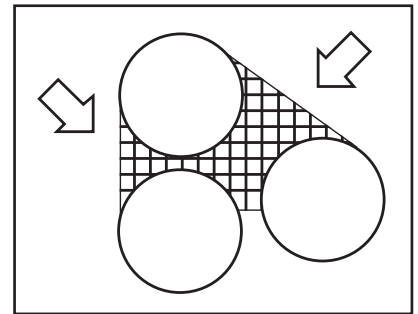

Keep the instruction manual of the machine in a safe place.

The instruction manual contains important information that besides the safety information also give important information regarding operation, service, maintenance etc.

Modification of the machine

All conversion, modification or change of this machine is strictly forbidden with the exception of

- Original spare parts
- Optional equipment supplied by the manufacturer.

Falling workpieces

Be careful when working with heavy workpieces so that they do not fall down by mistake when the grip loosens between the upper and lower rolls (see figure). If necessary use a support table, travelling crane or some other lifting device.

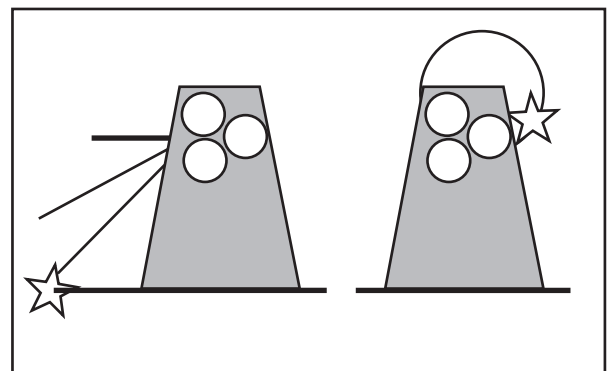

SAFETY



Pinching risk of the workpiece

Note that there is a pinching risk between the ends of the workpiece, see figure.

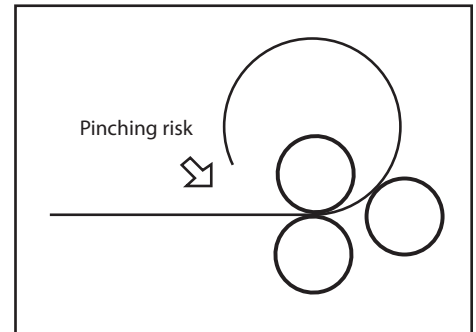

Gearing protection

All machine transmissions are completely covered by fixed protections.

Note! The machine must not be run if one of these protections has been removed.

Service and maintenance

Before service and maintenance are carried out on the machine you must have had instructions from your foreman. You must also read and understand this instruction manual. If the machine must be dismantled, completely or partly, contact your foreman.

Protective clothing

Important! Never use gloves when bending, as this considerably increases the risk of getting pinched between the rolls.

For other handling of the workpieces use gloves. The operator must not carry belts, rings or necklaces.

Working shoes with steel inserts must be used.

Loose hanging clothes must not be used.

If the operator has long hair, this must not hang loose.

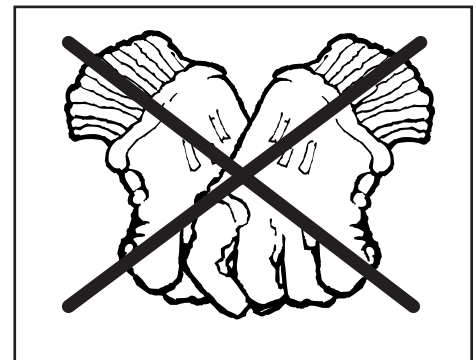

Deburring of the workpiece

Burrs and sharp edges must be removed from the workpiece before bending.

Safety in general

The chapters describing the safety devices are based on the assumption that the machine is used in the manner described in this instruction manual, that the operator has got the necessary information regarding the safety of the machine as well as the special risks involved with this type of machine.

If the machine is not used in the proper way, the manufacturer cannot be held responsible for personal injuries or material damages, which may be the result. Also check the following:

- Take all necessary safety precautions when loading, setting, changing spare parts, cleaning, repairing and servicing so that the exposed person cannot start the machine.
- Do not disconnect the safety devices of the machine.
- Do not remove any part of the machine belonging to the safety devices.
- Always check that all safety devices have been remounted after repair work etc.

SERVICE AND MAINTENANCE

Installation

The machine must be placed on firm ground e.g. cemented floor. The ground must be level in order to avoid tensions in the machine when fixing it to the floor.

Maintenance

The machine is delivered with greased bearings for about 200 hours' continuous duty. After this period it should be lubricated with ball bearing grease of good quality, e.g. Esso Multi purpose grease H or equivalent.

See also section on Lubrication / grease chart.

LUBRICATION / GREASE CHART

Lubrication points

There are in total 10 lubrication points:

1. Front left side, 3 points.
2. Front right side, 2 points.
3. Rear left side, 2 points.
4. Rear right side, 2 points.
5. Bearing point.

See images for the locations of the lubrication points.

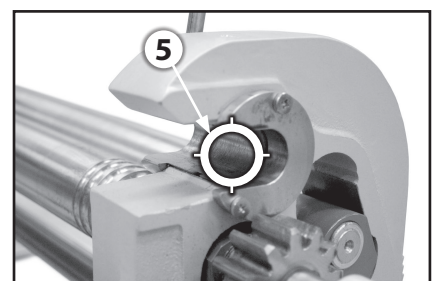
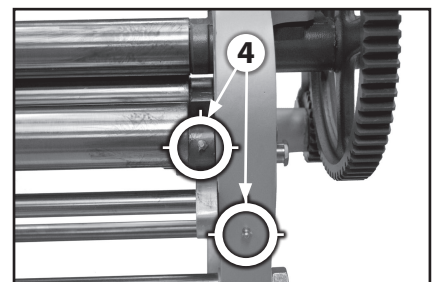
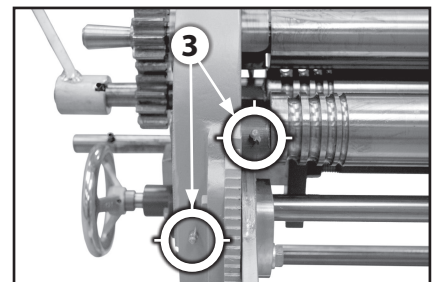
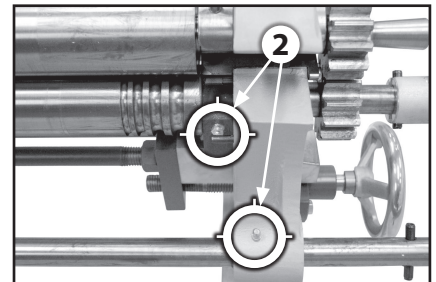
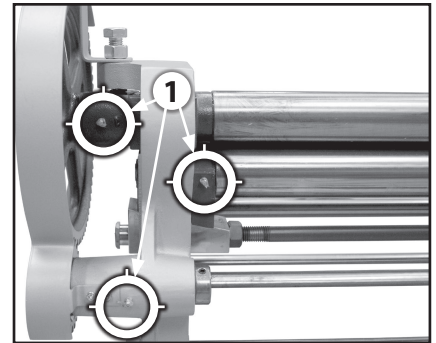

MACHINE PLATES AND STICKERS

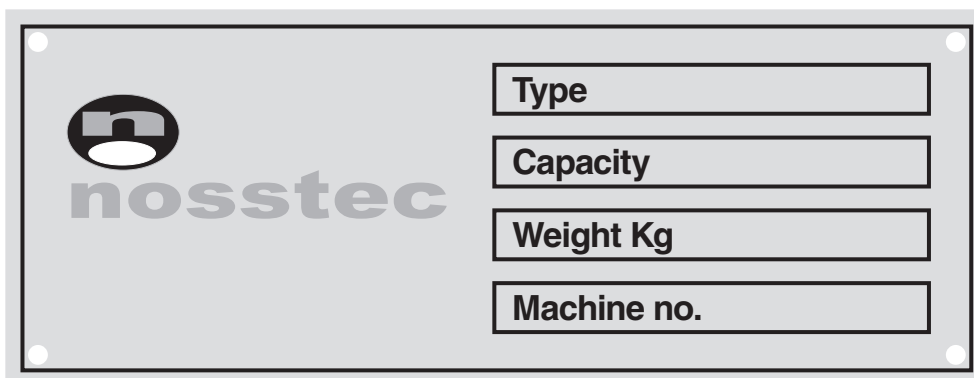

Aluminium plate, blue anodized text.

DISMANTLING OF THE MACHINE

This instruction is made in order to support trained staff when repairing with a view to minimizing the risk of personal injuries and damage to the machine.

To enable dismantling of the machine in a safe way, the job must be carried out by at least two trained mechanics.

This dismantling instruction must not be kept together with the machine. The proper holder is the supervisor and/or service staff.

Procedure:

1. Dismount the protective cover.
2. Disassemble the gears using a puller.
3. Swing out the upper roll out of the bearing housing. Place a lifting strap in the middle of the upper roll and gently pull it out of the opposite bearing housing. Place it e.g. on a bench.
4. Dismount the gear for the lower roll.
5. Loosen the two nuts on the stand.
6. Loosen the nuts and dismount the wedge.
7. Lower the lifting strap around the lower rolls and fixate them by means of a strong flat iron between the rolls.
8. Pull out the stand and remove the shafts.
9. Place a strong support under the detached roll ends (**Note: not under the roll necks**), and place the lifting strap under the centre of gravity of one of the rolls. Pull the roll out of the frame, lift it down and place it on e.g. a bench. Repeat this procedure with the other lower roll.

NOTE: Handle the loose parts carefully and check that all pieces removed also are mounted in their right places, but in the reverse order.

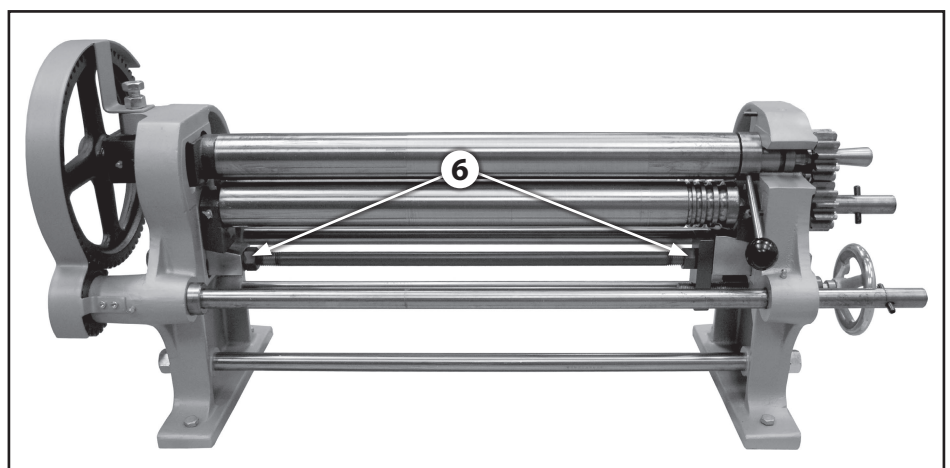
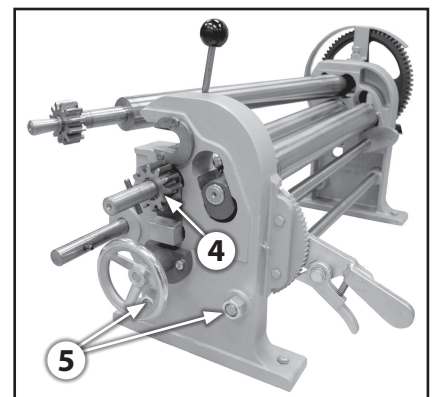
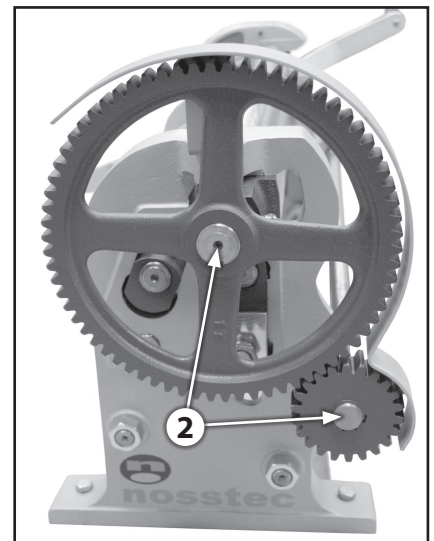
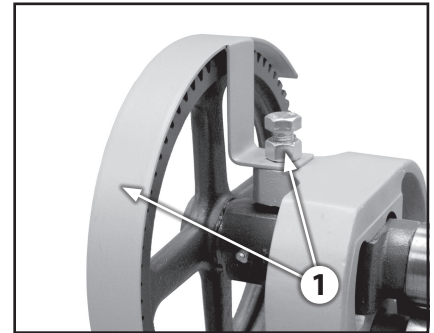



A series of horizontal dotted lines for taking notes.



nosstec

www.nosstec.se

Nosstec AB • Kristineholmsvägen 12, 441 39 Alingsås, SWEDEN
Tel: +46 (0)512 298 85 • Fax: +46 (0)512 298 89 • E-mail: info@nosstec.se

For copyright reasons all reproduction and copying of the texts, photos, tables and illustrations within this manual is prohibited without written permission from Nosstec AB.